

Cable Support and Fixing Systems



Linking the future

As the worldwide leader in the cable industry, Prysmian Group believes in the effective, efficient and sustainable supply of energy and information as a primary driver in the development of communities.

With this in mind, we provide major global organisations in many industries with best-in-class cable and accessory solutions, based on state-of-the-art technology. Through two renowned commercial brands - Prysmian and Draka - based in almost 50 countries, we're constantly close to our customers, enabling them to further develop the world's energy and telecoms infrastructures, and achieve sustainable, profitable growth.

In our energy business, we design, produce, distribute and install cables and systems for the transmission and distribution of power at low, medium, high and extra high voltage.

In telecoms, the Group is a leading manufacturer of all types of copper and fibre cables, systems and accessories - covering voice, video and data transmission.

Drawing on over 130 years' experience and continuously investing in R&D, we apply excellence, understanding and integrity to everything we do, meeting and exceeding the precise needs of our customers across all continents, at the same time shaping the evolution of our industry.



What links the oil and gas industry from end to end?

Cable solutions to support the sector around the world

In applications ranging from drilling, extraction and storage equipment to platform and processing facilities operation, Prysmian's state-of-the-art cable systems support many major customers in the oil, gas and petrochemical industry, along with related businesses.

Whether they're deployed in Brazil, the Gulf of Mexico, the North Sea or South-East Asia, our cable solutions are proving their value in harsh offshore and onshore environments; helping customers minimize environmental impact and achieve sustainable, profitable growth.

Prysmian Group's dedicated Components facility based in Wrexham, Wales manufactures and supplies the market with products which are widely used in industrial, commercial and domestic power distribution systems. In addition it offers products for more specialist applications such as Utilities, Railways, Oil, Gas and Petrochemical, Hazardous Areas, Wind and Solar Energy. Today's BICON® product ranges represent over 100 years of cable accessory development and quality engineering building on the pedigree of our previous company names - going back to BICC. Of course Prysmian Group's Components products are the

perfect installation accessory for the Company's vast range of quality, approved cables.

Prysmian Group's comprehensive component product range includes:

- BICON® Cable Glands
- BICON® Cable Cleats
- BICAST® Joints & Terminations
- BICON® Connectors and Tooling
- Flexo® Modular Power Systems
- Flexo® Rail products
- JEM™ Resin
- Connecta System®

From its UK base, Prysmian Group's Components is able to efficiently service the needs of its UK and overseas customers and offers a high level of pre-sales and post-sales customer service.

For further information please contact:

International Sales Office: **+44 2380 295481**
www.biconcomponents.co.uk



Prysmian Group's Components business unit, based in Wrexham, is the UK's leading manufacturer of Cable Support and Fixings Systems and offers a range that is both comprehensive and diverse. Through many years of industry experience and working closely with our customers, Prysmian Group is able to offer cleats to support and fix all cable types on the market.

Our accessory range has been designed and tested with The Prysmian Group cable products and are recommended as the preferred method of installation.

The ever popular two-bolt, hook, telcleat and claw cleats are available in a range of materials to suit a variety of applications, including heavy duty variants. Our patented Multicleat/Multistrap system and the Trefoil families offer installers several viable options for Trefoil installations.

When installing fire resistant and Low Smoke Zero Halogen cables it is important that the accessories used meet the same performance requirements as the cable so as not to impact on the system

performance in case of fire. As the UK's market leader in both of these types of cables it is no surprise that the Prysmian Group is able to offer specific fixing solutions. Look out for the FP, Afumex, FT and Saffire logos in the catalogue which highlight these.

A thermoset epoxy coating is available on all our ranges of aluminium cleats and bases, and can be specified where consideration as to the nature of the environment is one of prime concern. It offers outstanding protection in areas containing a combination of one or more of the following: saline, chemical attack, pollution, high humidity and/or high ambient temperatures.

Our cleats have been used on a vast number of major electrical engineering projects including: the Channel Tunnel, Gorgon LNG, PEARL, London Heathrow T5, Helwyn Windfarm and the Woodhead Tunnel.

Cleat selection

Cables can be mounted on supports in many ways, however if cable cleats are correctly used to do this they will satisfy the requirements of the IET 17th Edition Wiring Regulations.

522.8.4 "Where the conductors or cables are not supported continuously due to the method of installation, they shall be supported by suitable means at appropriate intervals in such a manner that the conductors or cables do not suffer damage by their own weight." (1)

522.8.5 "Every cable and conductor shall be supported in such a way that it is not exposed to undue mechanical strain and so that there is no appreciable mechanical strain on the terminations of the conductors, account being taken of the mechanical strain imposed by the supported weight of the cable or conductor itself." (1)

(1) 522.8.4, 522.8.5 extracts from BS 7671 – IET 17th edition wiring regulations

Cable cleats also offer the following additional advantages:

- They facilitate a neat and orderly installation allowing cables to be used at their optimum ratings whilst maximising the use of available space.
- They maintain cables in position making reworking easier and potentially safer.
- They provide restraint against short circuit forces.

This catalogue is designed to direct you to the most suitable Prysmian Components cleat for your application.

The logic tree below shows the decisions that need to be made in order to specify the correct cleat for a specific installation.

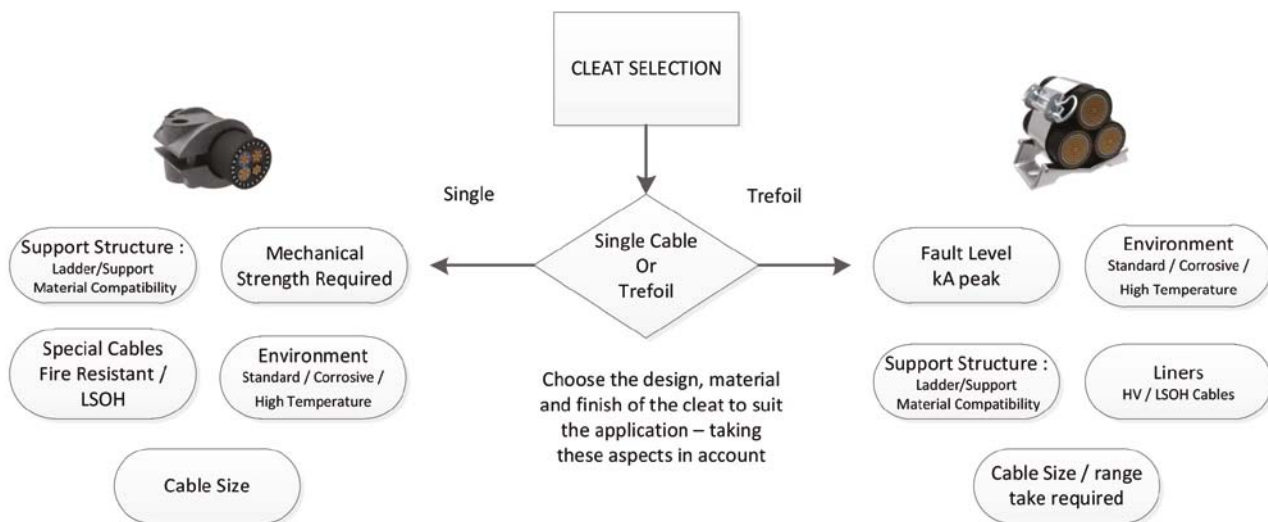

The first decision is whether or not the arrangement is a single cable or a trefoil grouping:

- When fixing a single cable the cleats should be installed in line with the IET 17th Edition – guide to use table.
- When fixing trefoil groups the controlling factor becomes the system short circuit rating and cleats should be selected and spaced according to their short circuit performance.

Contents

Introduction

Linking the Future	2
Introduction to cable support and fixing systems	3
Cleat selection	4
Correct spacing	6 - 7
Approvals and Standards	7

Single Way Cleats

Telcleat	8
Afumex Telcleat (LSOH)	9
Ranger Cleat	10
Heavy Duty Hook Cleat	11
Plastic Two Bolt Cleat	12
Afumex Two Bolt Cleat (LSOH)	13
Hook Cleat (Aluminium)	14
Claw Cleat (Aluminium)	15
Two Bolt Cleat (Aluminium)	16
Rubber Lined Cleats (Aluminium)	17
Shoe Cleat	18
Linear Short Circuit Straps	19
Heavy Duty Two Bolt Cleat (Aluminium)	20
Orbit Cleat	21

Fire Resistant Cleats

Firefix Single Clip	22
Firefix Double Clip	23
AP Clips	24
Claw Cleat (Cast Iron)	25
Two Bolt Cleat (Cast Iron)	26

Trefoil Cleats

Multicleat / Multistrap System	27 - 29
Sirius Cleat	30 - 31
Orion Cleat	32
Orion Cleat - Shaped	33
Libra Cleat	34
Orion Strap / Sirius Strap	35

Bespoke Solutions

Installation Equipment	36
System Repair Cleat	37
Auxiliary Stand Off	37
Miscellaneous Arrangements	37

Accessories

Cable Ties	38
Insulating Pad, Adaptor Plate and Packing Piece	39

Correct Spacing

Single Cables

Spacings of supports for cables in accessible positions

Maximum spacings of cable fixings						
Overall diameter of cable*	Non-armoured thermosetting, thermoplastic or lead sheathed cables and non-armoured fire resisting cables.		Single wire armoured cables including fire resisting armoured cable		Mineral insulated copper sheathed or aluminium sheathed cables	
	Horizontal† 2	Vertical† 3	Horizontal† 6	Vertical† 7	Horizontal† 8	Vertical† 9
mm	mm	mm	mm	mm	mm	mm
Not exceeding 9	250	400	-	-	600	800
Exceeding 9 and not exceeding 15	300	400	350	450	900	1200
Exceeding 15 and not exceeding 20	350	450	400	550	1500	2000
Exceeding 20 and not exceeding 40	400	550	450	600	-	-
Exceeding 40 and not exceeding 50	600	800	900	1100	-	-
Exceeding 50 and not exceeding 60	750	1000	950	1100	-	-
Exceeding 60 and not exceeding 70	900	1200	1000	1200	-	-
Exceeding and above	1000	1400	1200	1400	-	-

Note:

Fire resistant fixings should be used for fire resistant cables.

* For flat cables taken as the dimension of the major axis.

The spacings shown above apply to multi-core cables.

The spacing of fixings on single core cables in a.c. installations must take account of the magnitude of forces generated under fault conditions.

† The spacings stated for horizontal runs may be applied also to runs at an angle of more than 30° from the vertical.

For runs at an angle of 30° or less from the vertical, the vertical spacings are applicable.

Cleating Cables in Trefoil

When a short circuit fault occurs in a three phase system, there is at first a period of extreme asymmetry which is then followed by a steadier more symmetrical state.

The degree of asymmetry depends on when in the cycle the fault is initiated and also the nature of the fault, e.g. three phase to earth. By convention, the "Peak" is the maximum current value achieved in the early asymmetrical period and it is at this point that the highest instantaneous force between the cables occurs.



BS EN 61914:2009 (IEC 61914) provides a formula which enables us to calculate the maximum force on a cable conductor.

$$F_t = 0.17 \cdot i_p^2 / S \quad (B.4)$$

F_t	is the maximum force on the cable conductor in a trefoil configuration for a three phase short circuit [N/m]
i_p	is the peak short-circuit current [kA]
S	is the centre to centre distance between two neighbouring conductors [m] (for Trefoil arrangements $S = \text{Cable Diameter}$)

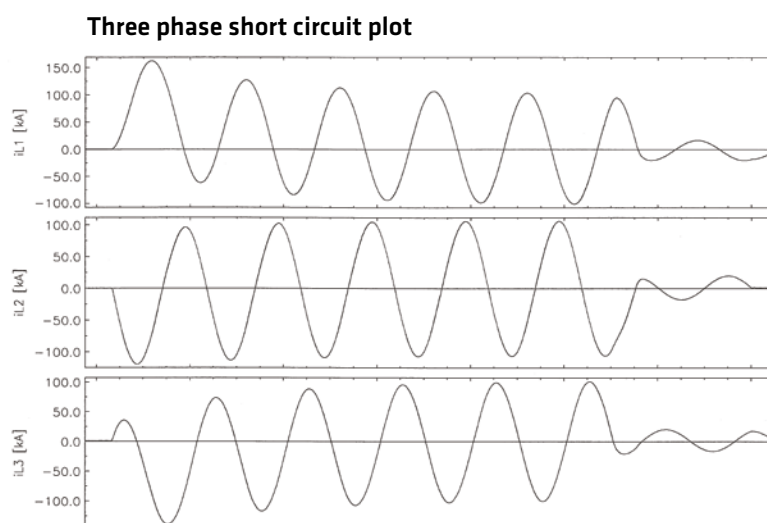

Short circuit tests in accordance with BS EN 61914:2009 are performed on the most critical cleat size within its range; the Formula (B.4) can then be used to calculate the maximum force generated during the test. This maximum force figure can then be used when specifying alternative configurations of cable size and fault current – calculating the theoretical F_t for the alternative configuration and ensuring that it is less than or equal to the as tested value.

Trefoil Cleat Spacing

Trefoil cleats that are required to withstand the high forces generated by high short circuit currents will often be spaced at very regular intervals – typically matching the commonly available cable ladder (i.e. 300mm / 225mm).

The maximum short circuit current values will be quoted with the test information for each design of trefoil cleat - if a system uses larger cables or has a lower fault current it may be possible to broaden these spacings - (contact the Prysmian technical team).

As a general rule in order to create and maintain a satisfactory trefoil installation a maximum strap/cleat spacing of 900mm is preferred.

Approvals, Testing and Standards

For many years there were no British or International standards for cable cleats; Prysmian Components were actively involved in the creation of the European Standard and in progressing the standard through to it being published as the current international standard BS EN 61914:2009 (IEC 61914).

Our cleats have been tested by independent testing authorities including:

- BSTS (ASTA)
- ERDA (ASTA)
- CPRI (ASTA)
- IPH CESI (ASTA)
- ZKU

We also hold third party test reports for our LSOH cleats detailing compliance with LUL requirements. Many of our cleats have Network Rail PADS approval numbers. Contact the Prysmian technical team for more information.



Telcleat® 385 series

- Suitable for use with cable diameters 10 to 51mm.
- Manufactured from Low Density Polythene.
- Overlapping self-adjusting ranges.
- Sunlight (UV) and weather resistant.
- One piece, single fixing design.
- Can be double stacked on a single fixing.
- Operating temperature -40°C to +60°C.
- Tested in accordance with BS EN 50368.

Technical Data

Cable and Cleat Selection				Cleat Details						
Design Number	Cable Diameter		Standard Pack Quantities	Dimensions (mm)				Weight (g)	Roundhead woodscrew	Screw Bolt
	Min	Max		B Min	Max	C Max	D		masonry, concrete or wood ins x No	for Cable Tray mm
385AA01	10.5	14.5	100	15	18	32	12	2.3	1 1/4 x 8	M4 x 30
385AA02	12.2	16.7	100	17	22	36	14	3.4	1 1/2 x 8	M4 x 35
385AA03	14.6	19.8	100	21	26	43	16	5.5	1 3/4 x 8	M4 x 40
385AA04	17.7	24.0	50	25	31	51	18	8.6	2 x 8	M4 x 45
385AA05	21.7	28.5	25	30	37	57	20	12.4	2 1/4 x 12	M6 x 50
385AA06	26.2	34.2	25	35	43	65	22	16.4	2 1/2 x 12	M6 x 60
385AA07	31.9	41.6	10	42	52	78	25	24	2 3/4 x 12	M6 x 70
385AA08	39.3	51.1	10	50	62	91	26	35	3 1/4 x 12	M6 x 80

Method of Fixing

The cleat is opened up and placed around the cable so that the end of the cleat containing the slot will be in contact with the mounting surface, except for the 385AA01, which should be reversed to put the slot uppermost. In this case an M5 washer should be used to prevent the nut entering the slot of the cleat.

When mounting directly on channel section an adaptor plate should be used (please see page 39).

Performance Data

Test Standard	EN 50368:2003
Type	6.1.2 Non-Metallic
Impact Resistance	6.2.4 Heavy -> 6.2.5 V. Heavy
Lateral Load	0.188 -> 0.775 kN
Axial Load	0.046 -> 1.118 kN
Needle Flame	>60 secs

* Technical Information subject to change without notice

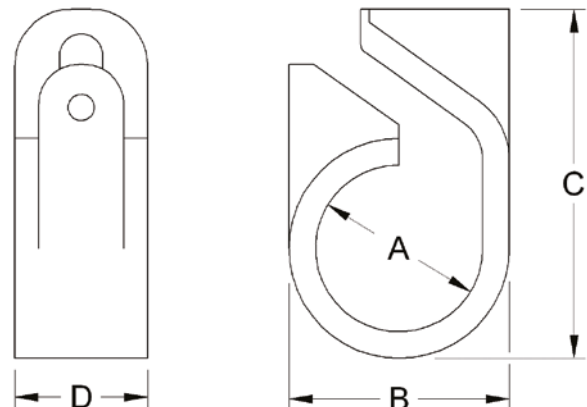



Afumex Telcleat[®] (LSOH) 385 series

- Suitable for use with cable diameters 10 to 51mm.
- Manufactured from LSOH polymer.
- Designed for use with Afumex LSOH and Saffire OHLS cables.
- Overlapping self-adjusting ranges.
- Sunlight (UV) and weather resistant.
- One piece, single fixing design.
- Can be double stacked on a single fixing.
- Operating temperature -40°C to +40°C.
- Tested in accordance with BS EN 50368.
- LUL approved product register ID 1259.

Technical Data

Afumex SAFFIRE^{OHLS}

Cable and Cleat Selection				Cleat Details						
Design Number	Cable Diameter		Standard Pack Quantities	Dimensions (mm)				Weight (g)	Roundhead woodscrew masonry, concrete or wood ins x No	Screw Bolt for Cable Tray mm
	Min	Max		Min	Max	Max				
385LSF01	10.5	14.5	100	15	18	32	12	3.3	1 1/4 x 8	M4 x 30
385LSF02	12.2	16.7	100	17	22	36	14	5.6	1 1/2 x 8	M4 x 35
385LSF03	14.6	19.8	100	21	26	43	16	9.5	1 3/4 x 8	M4 x 40
385LSF04	17.7	24.0	50	25	31	51	18	14.7	2 x 8	M4 x 45
385LSF05	21.7	28.5	25	30	37	57	20	20.4	2 1/4 x 12	M6 x 50
385LSF06	26.2	34.2	25	35	43	65	22	29.2	2 1/2 x 12	M6 x 60
385LSF07	31.9	41.6	10	42	52	78	25	36.7	2 3/4 x 12	M6 x 70
385LSF08	39.3	51.1	10	50	62	91	26	58.1	3 1/4 x 12	M6 x 80

Method of Fixing

The cleat is opened up and placed around the cable so that the end of the cleat containing the slot will be in contact with the mounting surface, except for the 385LSF01, which should be reversed to put the slot uppermost. In this case an M5 washer should be used to prevent the nut entering the slot of the cleat.

When mounting directly on channel section an adaptor plate should be used (please see page 39).

Performance Data

Test Standard	EN 50368:2003
Type	6.1.2 Non-Metallic
Impact Resistance	6.2.4 Heavy -> 6.2.5 V. Heavy
Lateral Load	0.136 -> 0.781 kN
Axial Load	0.119 -> 1.024 kN
Needle Flame	>120 secs

* Technical Information subject to change without notice

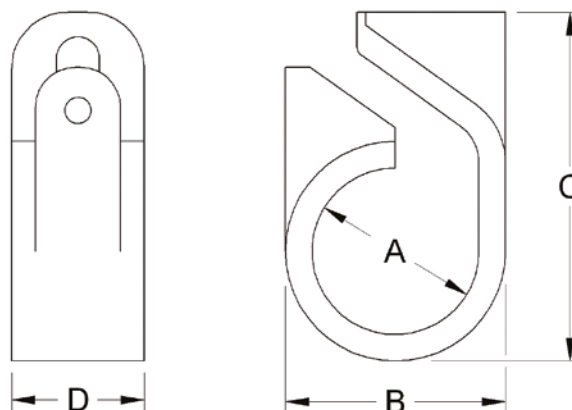

SINGLE WAY CLEATS

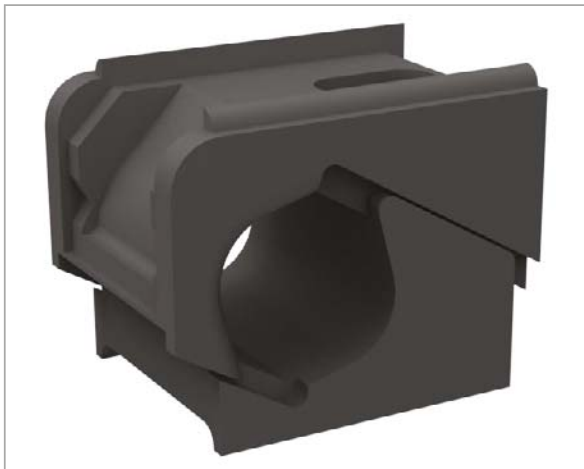

Ranger® Cleat 382 series

- Suitable for use with cable diameters 13 to 76mm.
- Overlapping, self-adjusting ranges.
- Sunlight (UV) and weather resistant.
- Made from ABS which provides good oil and chemical resistance.
- Two piece, single bolt fixing.
- Double stacking facility.
- Operating temperature -20°C to +90°C.
- 'C' Section channel location aids fixing and stacking.
- Not designed for long vertical runs.

Technical Data

Cable and Cleat Selection			Cleat Details					SWL FOS2 (kgf)	Weight (g)
Design Number	Cable diameter		Dimensions (mm)						
	A (mm)		B	C	D	E			
	Min	Max	Max						
382AA01	13	18	35.5	47	49	18	300	51	
382AA02	17	22	40	47	54	20	260	52.5	
382AA03	21	28	45	47	62	24	295	63	
382AA04	27	37	53	47	67	30	167	76	
382AA05	36	51	69	47	92	36	158	121	
382AA06	50	76	92	47	111	52	110	193	

Method of Fixing

In all applications the cleat should be mounted on suitable M10 fixings. There is no need for any channel adaptor when mounting directly on to 'C' section channel.

SWL data based upon the use of commercial grade 4.6 mild steel.

SWL = Safe working load.

FOS 2 = Values include a factor of safety of 2.

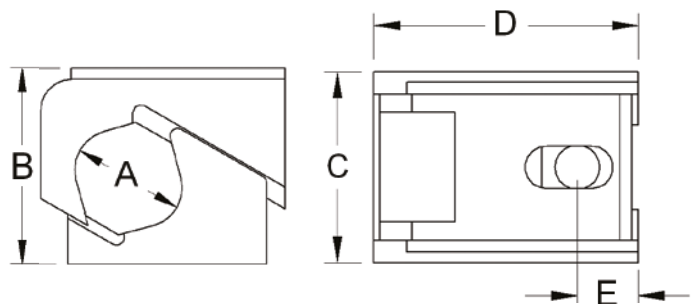



Heavy Duty Hook Cleat 384 series

- Suitable for use with cables diameters 25 to 80mm.
- Manufactured from glass-filled nylon.
- Two-piece, single fixing design.
- Can be double stacked on a single fixing.
- Can be installed in temporary open position to aid single person working.
- All sizes secured with 10mm fixings.
- Operating temperature -25°C to +85°C.
- For normal industrial use indoor and outdoor.
- Fits most ladder and tray systems.
- Not designed to secure cables in long vertical routes.
- Tested in accordance with BS EN 50368.

SINGLE WAY CLEATS

Technical Data

Cable and Cleat Selection			Cleat Details					
Design Number	Cable Diameter		Dimensions (mm)					Weight (g)
	A (mm)		B		C	D	E	
Nylon	Min	Max	Min	Max				
384AA01	25	35	36	46	76	40	18	63
384AA02	34	44	44	54	85	40	18	74
384AA03	43	53	56.5	66.5	96	40	18	105
384AA04	52	62	65.5	75.5	106	40	18	129
384AA05	61	71	78	88	119	44	20	175
384AA06	70	80	87	97	129	44	20	221

Method of Fixing

In all applications the cleat should be mounted on suitable M10 fixings. There is no need for any channel adaptor when mounting directly on to 'C' section channel.

Performance Data

Test Standard	EN 50368:2003
Type	6.1.2 Non-Metallic
Impact Resistance	6.2.4 Heavy -> 6.2.5 V. Heavy
Lateral Load	1.320 -> 1.5 kN
Axial Load	82 -> 109 N
Needle Flame	>120 secs

* Technical Information subject to change without notice

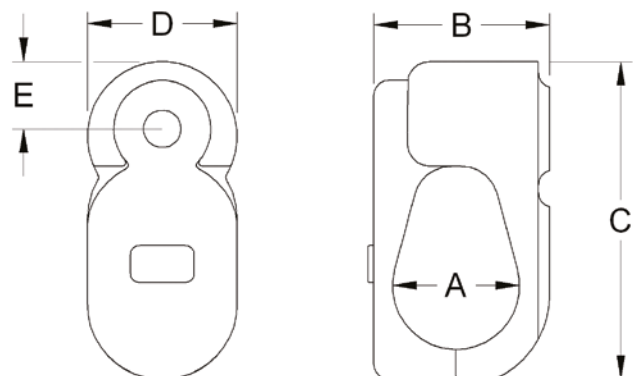



Plastic Two Bolt Cleat 374 series

- Suitable for use with cable diameters 50 to 94mm.
- Manufactured from black high-density nylon 66.
- Unaffected by corrosive environments such as oils and many chemicals.
- Sunlight (UV) and weather resistant.
- Two-piece, two fixing design.
- Can be double stacked on common fixings.
- Operating temperature -25°C to +85°C.
- Tested in accordance with BS EN 50368.

SINGLE WAY CLEATS

Technical Data

Cable and Cleat Selection			Cleat Details				Weight (g)
Design Number	Cable diameter		Dimensions (mm)				
	A (mm)		B	C	D	E	
	Min	Max	Max				
374AA01	50	58	89	102	45	80	97
374AA02	56	64	93	102	45	80	98
374AA03	62	70	98	114	45	92	106
374AA04	68	76	104	114	50	92	132
374AA05	74	82	110	126	50	104	154
374AA06	80	88	118	126	50	104	160
374AA07	86	94	121	136	60	114	204

Method of Fixing

In all applications the cleat should be mounted on suitable M10 fixings. There is no need for any channel adaptor when mounting directly on to 'C' section channel.

Performance Data

Test Standard	EN 50368:2003
Type	6.1.2 Non-Metallic
Impact Resistance	6.2.4 Heavy -> 6.2.5 V. Heavy
Lateral Load	10.9 -> 14.8 kN
Axial Load	198 -> 494 N
Needle Flame	>120 secs

* Technical Information subject to change without notice

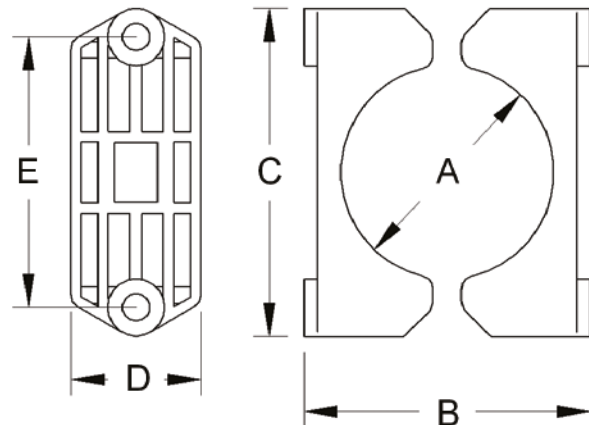



Afumex Two Bolt Cleat (LSOH) 374 series

- Suitable for use with cable diameters 50 to 94mm.
- Manufactured from LSOH Polymer.
- Designed for use with Afumex LSOH and Saffire OHLS cables.
- Low Smoke and Zero Halogen.
- Sunlight (UV) and weather resistant.
- Two-piece, two fixing design.
- Can be double stacked on common fixings.
- Operating temperature -40°C to +60°C.
- Tested in accordance with BS EN 50368.
- LUL approved product register ID 1958.

SINGLE WAY CLEATS

Technical Data

Afumex SAFFIRE^{OHLS}

Cable and Cleat Selection			Cleat Details					
Design Number	Cable Diameter		Dimensions (mm)					Weight (g)
	A (mm)		B	C	D	E		
	Min	Max	Max					
374LSF01	50	58	89	102	45	80	174	
374LSF02	56	64	93	102	45	80	158	
374LSF03	62	70	98	114	45	92	174	
374LSF04	68	76	104	114	50	92	210	
374LSF05	74	82	110	126	50	104	254	
374LSF06	80	88	118	126	50	104	264	
374LSF07	86	94	121	136	60	114	326	

Method of Fixing

In all applications the cleat should be mounted on suitable M10 fixings. There is no need for any channel adaptor when mounting directly on to 'C' section channel.

Performance Data

Test Standard	EN 50368:2003
Type	6.1.2 Non-Metallic
Impact Resistance	6.2.5 V. Heavy
Lateral Load	1.22 -> 3.485 kN
Axial Load	82 -> 110 N
Needle Flame	>120 secs

* Technical Information subject to change without notice

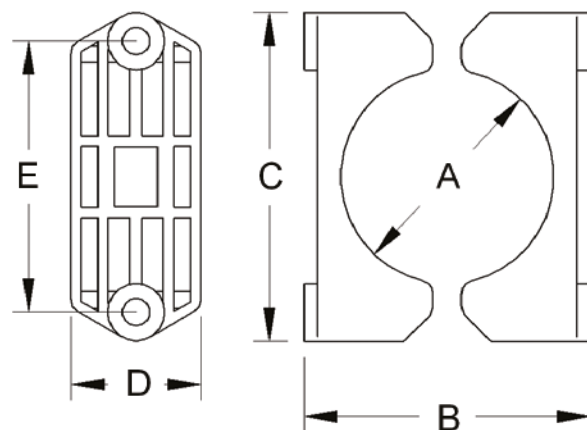



Hook Cleat (Aluminium) 371 series

- Suitable for use with cable diameters 19 to 76mm.
- Manufactured from aluminium alloy.
- Self-adjusting ranges.
- Two-piece, single fixing design.
- Can be double stacked on a single fixing.
- Can be installed in temporary open position to aid single person working.
- Suitable for indoor dry normal industrial use or outdoor unpolluted areas.
- Operating temperature -60°C to +105°C.
- Not designed to secure cables in long vertical routes.
- LUL approved product register ID 1962.

SINGLE WAY CLEATS

Technical Data

Cable and Cleat Selection			Cleat Details						
Design Number	Cable diameter		Dimensions (mm)						Weight (g)
	A (mm)		B		C	D	E	F	
	Min	Max	Min	Max					G
371AA03	19	22	29	33	57	38	24	19	57
371AA04	22	25	34	37	62	38	26	19	71
371AA05	25	32	37	45	74	45	29	24	106
371AA06	32	38	44	50	81	45	32	24	113
371AA07	38	44	50	57	88	45	35	24	142
371AA08	44	51	55	63	94	45	38	24	142
371AA09	51	57	64	72	103	45	43	24	191
371AA10	57	64	72	79	111	45	48	24	213
371AA11	64	70	80	91	124	45	53	25	291
371AA12	70	76	91	96	132	45	57	27	326

Method of Fixing

In all applications the cleat should be mounted on suitable M10 fixings.

When mounting directly on "Unistrut" or "Leprack" type channel, adaptor plate 380AC02 should be used (please see page 39).

Performance Data

Test Standard	EN 50368:2003
Type	6.1.1 Metallic
Impact Resistance	6.2.5 V. Heavy
Lateral Load	1.32 -> 1.5 kN
Axial Load	82 -> 109 N
Needle Flame	>120 secs

* Technical Information subject to change without notice

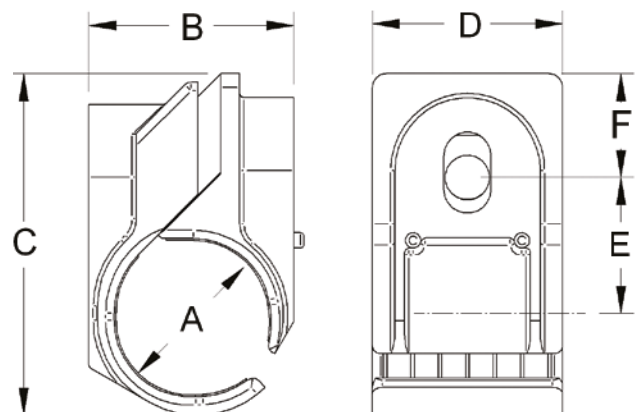



Claw Cleat (Aluminium) 370 series

- Suitable for use with cable diameters 10 to 51mm.
- Manufactured from aluminium alloy.
- Two-piece, single fixing design.
- Can be stacked to a maximum of three on one fixing.
- Operating temperature -60°C to +105°C.
- Can be used for all types of cable routes.
- Plain finish - for normal industrial areas or outdoor unpolluted areas.
- Epoxy coated versions available for harsher environments.
- Packing pieces to be used where required.
- LUL approved product register ID 1959.

SINGLE WAY CLEATS

Technical Data

Cable and Cleat Selection				Cleat Details					
Design Number		Cable diameter		Dimensions (mm)				Weight (g)	Stud Size
Standard	Epoxy Coated	A (mm)		B	C	D	E		
		Min	Max	Max					
370BA01	370BB01	10	13	21	38	46	16	60	M10
370BA02	370BB02	13	16	21	38	46	16	50	M10
370BA03	370BB03	16	19	24	41	46	18	60	M10
370BA04	370BB04	19	22	27	44	46	19	70	M10
370BA05	370BB05	22	25	30	48	46	21	80	M10
370BA06	370BB06	25	32	37	54	46	24	90	M10
370BA07	370BB07	32	38	43	60	46	27	110	M10
370BA08	370BB08	38	44	49	67	46	30	120	M10
370BA09	370BB09	44	51	56	73	46	34	150	M10

Method of Fixing

In all applications the cleats should be mounted on suitable M10 fixings. When mounting directly on channel, adaptor plate 380AG02 should be used. When stacking claw cleats use packing piece 389AC03 between cleats. (Please see page 39 for selecting both of these items.)

Performance Data

Test Standard	EN 50368:2003
Type	6.1.1 Metallic
Impact Resistance	6.2.5 V. Heavy
Lateral Load	3.7 -> 8.2 kN
Axial Load	1.332 -> 5.855 kN
Needle Flame	>120 secs

* Technical Information subject to change without notice

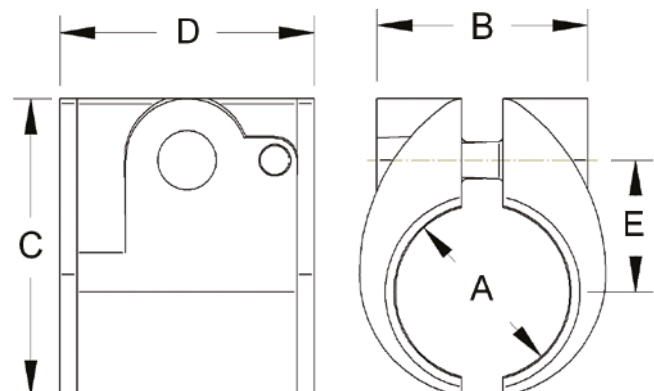



Two Bolt Cleat (Aluminium) 370 series

- Suitable for use with cable diameters 51 to 159mm.
- Manufactured from aluminium alloy.
- Two-piece, two fixing design.
- Can be double stacked on common fixings.
- Operating temperature -60°C to +105°C.
- Suitable for LV & HV cables.
- Can be used for all types of cable routes.
- Plain finish - for normal industrial areas or outdoor unpolluted areas.
- Epoxy Coated versions available for harsher environments.
- Optional rubber liners available.
- Tested in accordance with BS EN 50368.
- LUL approved product register ID 1963.

Technical Data

Cable and Cleat Selection				Cleat Details					Stud Size	Weight (g)
Design Number		Cable Diameter		Dimensions (mm)						
Standard	Epoxy Coated	A (mm)		B (mm)	C	D	E			
		Min	Max	Max						
370BA10	370BB10	51	57	70	98	49	76	M10	230	
370BA11	370BB11	57	64	76	98	49	76	M10	240	
370BA12	370BB12	64	70	82	135	64	114	M10	384	
370BA13	370BB13	70	76	88	135	64	114	M10	384	
370BA14	370BB14	76	83	96	140	64	114	M12	420	
370BA15	370BB15	83	89	101	140	64	114	M12	490	
370BA16	370BB16	89	95	108	152	76	126	M12	442	
370BA17	370BB17	95	101	114	152	76	126	M12	442	
370BA18	370BB18	101	108	120	165	76	140	M12	650	
370BA19	370BB19	108	114	126	165	76	140	M12	650	
370BA30	370BB30	115	121	133	175	100	150	M12	734	
370BA31	370BB31	121	127	139	175	120	150	M12	720	
370BA32	370BB32	127	133	145	200	120	175	M12	970	
370BA33	370BB33	133	140	152	200	120	175	M12	956	
370BA34	370BB34	140	146	158	200	120	175	M12	935	
370BA35	370BB35	146	152	164	210	120	185	M12	893	
370BA36	370BB36	152	159	172	215	150	190	M12	1325	

Method of Fixing

In all applications the cleat should be mounted on suitable fixings, see table for appropriate size. When mounting directly on channel, adapter plate 380AG02 should be used. (Please see page 39)

Performance Data

Test Standard	EN 50368:2003
Type	6.1.1 Metallic
Impact Resistance	6.2.5 V. Heavy
Lateral Load	18.1 kN
Axial Load	11.4 -> 13.8kN
Needle Flame	>120 secs

* Technical Information subject to change without notice

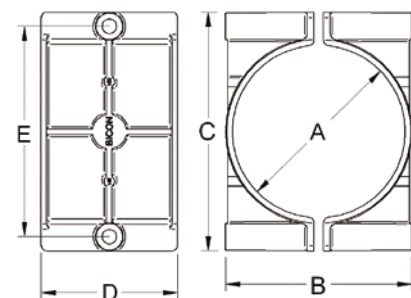



Rubber Lined Cleats (Aluminium) 370 series

- Suitable for use with cable diameters 16 to 149mm.
- Manufactured from aluminium alloy.
- Sizes 05-09 - Two piece, single fixing claw design.
- Sizes 10-36 - Two piece, two fixing design.
- Can be double stacked on common fixings.
- Operating temperature -60°C to +105°C.
- Suitable for LV & HV cables.
- Can be used for all types of cable routes.
- Plain finish - for normal industrial areas or outdoor unpolluted areas.
- Epoxy coated versions available for harsh environments.
- Tested in accordance with BS EN 50368.
- LUL approved product register ID 1963.

SINGLE WAY CLEATS

Technical Data

Cable and Cleat Selection				Cleat Details							
Design Number		Cable Diameter		Style	Dimensions (mm)				Weight (g)	Stud Size	Liner Thickness (mm)
Standard	Epoxy Coated	A (mm)			B	C	D	E			
		Min	Max		Max						
370BA05L	370BB05L	16	19	single bolt claw	30	48	46	21	90	M10	3
370BA06L	370BB06L	19	26		37	54	46	24	104	M10	3
370BA07L	370BB07L	26	32		43	60	46	27	127	M10	3
370BA08L	370BB08L	32	38		49	67	46	30	140	M10	3
370BA09L	370BB09L	38	45		56	73	46	34	173	M10	3
370BA10L	370BB10L	45	51		70	98	49	76	258	M10	3
370BA11L	370BB11L	51	58		76	98	49	76	272	M10	3
370BA12L	370BB12L	58	64		82	135	64	114	430	M10	3
370BA13L	370BB13L	64	70		88	135	64	114	435	M10	3
370BA14L	370BB14L	70	77		96	140	64	114	476	M12	3
370BA15L	370BB15L	73	79	101	140	64	114	585	M12	5	
370BA16L	370BB16L	79	85	108	152	76	126	561	M12	5	
370BA17L	370BB17L	85	91	two bolt	114	152	76	126	569	M12	5
370BA18L	370BB18L	91	98		120	165	76	140	787	M12	5
370BA19L	370BB19L	98	104		126	165	76	140	795	M12	5
370BA30L	370BB30L	105	111		133	175	100	150	943	M12	5
370BA31L	370BB31L	111	117		139	175	120	150	985	M12	5
370BA32L	370BB32L	117	123		145	200	120	175	1248	M12	5
370BA33L	370BB33L	123	130		152	200	120	175	1250	M12	5
370BA34L	370BB34L	130	136		158	200	120	175	1243	M12	5
370BA35L	370BB35L	136	142		164	210	120	185	1214	M12	5
370BA36L	370BB36L	142	149		172	215	150	190	1746	M12	5

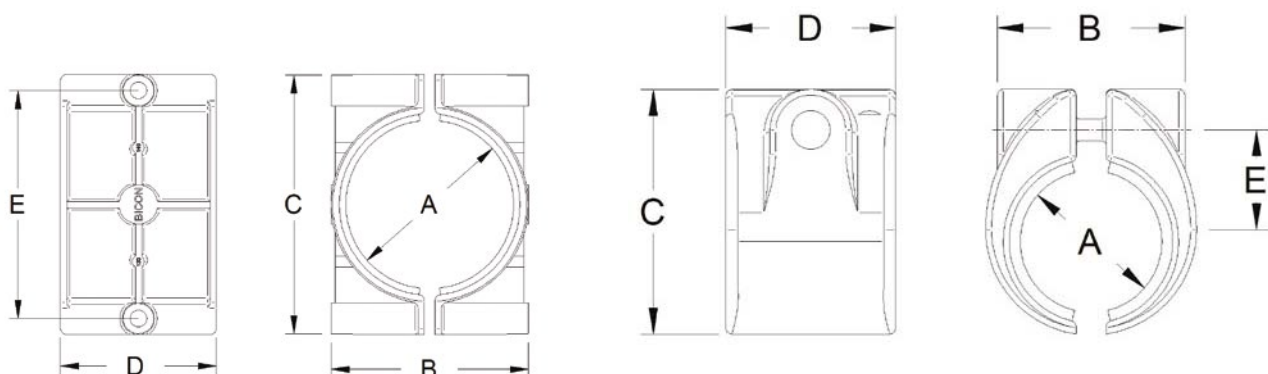



Shoe Cleat 370 series

In order to allow for the linear expansion of larger cables the support positions are often broadly spaced. Such broad spacing would put very high point loading on the cables which could lead to long term failure. The shoe cleats are designed to allow this potentially damaging load to be spread over a significantly longer length thus avoiding any potential cable damage. Based on the 370 series of aluminium 2 bolt cleats with the shoes made from 316L stainless steel with rubber lining. The shoes are designed and formed with the correct bend radius to match the cable's expansion curve.

Contact the Prysmian Components technical team who will be able to match the correct cleat and spacing to the size of cable and installation design.

Technical Data

Cable and Cleat Selection				Cleat Details			
Design Number		Cable Diameter		Stud Size	Bolt Centres	Length	Expansion Radius
Standard	Epoxy Coated	A (mm)					
		Min	Max		(mm)	(mm)	(mm)
370BA16SL	370BB16SL	79	85	M12	126	400	3000
370BA17SL	370BB17SL	85	91	M12	126	400	3000
370BA18SL	370BB18SL	91	98	M12	140	400	3000
370BA19SL	370BB19SL	98	104	M12	140	450	3000
370BA30SL	370BB30SL	105	111	M12	150	450	3000
370BA31SL	370BB31SL	111	117	M12	150	500	3000
370BA32SL	370BB32SL	117	123	M12	175	600	3000
370BA33SL	370BB33SL	123	130	M12	175	700	3000
370BA34SL	370BB34SL	130	136	M12	175	700	3000
370BA35SL	370BB35SL	136	142	M12	185	800	3000
370BA36SL	370BB36SL	142	149	M12	190	800	3000

Performance Data

Test Standard	EN 50368:2003
Type	6.1.1 Metallic
Impact Resistance	6.2.5 V. Heavy
Lateral Load	18.1 kN
Axial Load	11.4 -> 13.8kN
Needle Flame	>120 secs

* Technical Information subject to change without notice



Linear Short Circuit Straps

The linear short circuit straps can be used in horizontal or vertical installations. They can be designed and manufactured to user specified interaxial spacings. Options are available for them to be supplied with or without rubber liners to meet the cable system design requirements.

Contact the Prysmian Components technical team who will be able to match the correct cleat and spacing to the size of cable and installation design.

SINGLE WAY CLEATS

Technical Data

Cable and Cleat Selection				Cleat Details	
Aluminium Alloy		Epoxy Coated Aluminium Alloy		Cable diameter (mm)	
3 way	2 way	3 way	2 way	Min	Max
370SA16-xxx	370SA66-xxx	370SB16-xxx	370SB66-xxx	79	85
370SA17-xxx	370SA67-xxx	370SB17-xxx	370SB67-xxx	85	91
370SA18-xxx	370SA68-xxx	370SB18-xxx	370SB68-xxx	91	98
370SA19-xxx	370SA69-xxx	370SB19-xxx	370SB69-xxx	98	104
370SA30-xxx	370SA80-xxx	370SB30-xxx	370SB80-xxx	105	111
370SA31-xxx	370SA81-xxx	370SB31-xxx	370SB81-xxx	111	117
370SA32-xxx	370SA82-xxx	370SB32-xxx	370SB82-xxx	117	123
370SA33-xxx	370SA83-xxx	370SB33-xxx	370SB83-xxx	123	130
370SA34-xxx	370SA84-xxx	370SB34-xxx	370SB84-xxx	130	136
370SA35-xxx	370SA85-xxx	370SB35-xxx	370SB85-xxx	136	142
370SA36-xxx	370SA86-xxx	370SB36-xxx	370SB86-xxx	142	149

Replace 'xxx' with 300, 400, 500, 600, 700 for required cable separation.

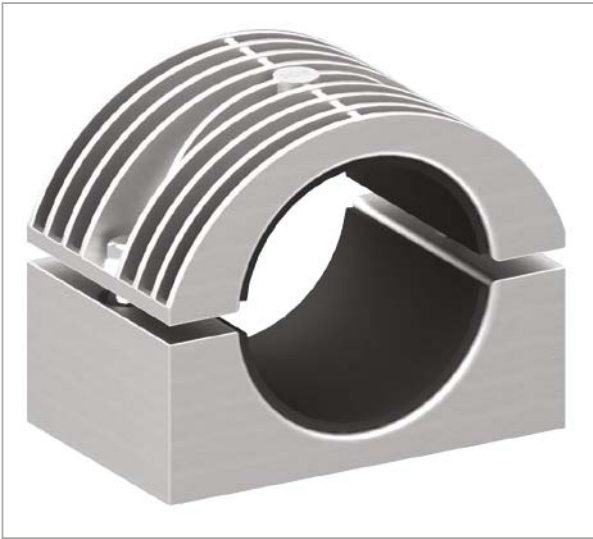

Heavy Duty Two Bolt Cleat (Aluminium) 370 series

- Ideally suitable for larger cables with diameters 100 to 159 mm.
- Manufactured from aluminium alloy.
- Two-piece, two fixing design.
- Operating temperature -60°C to +105°C.
- Designed to protect the cable sheaths during installation.
- Plain finish - for normal industrial areas or outdoor unpolluted areas.
- Epoxy coated versions available for harsher environments.
- Supplied with rubber liners.
- Tested in accordance with BS EN 61914.
- Spring loaded version available upon request.

SINGLE WAY CLEATS

Technical Data

Cable and Cleat Selection				Cleat Details				Weight (g)
Design Number		Cable Diameter		Dimensions (mm)				
Standard	Epoxy Coated	A (mm)		B	C	D (max)	E	
		Min	Max					
370HD01	370HE01	105	115	210	110	165	170	2517
370HD02	370HE02	115	125	220	120	175	180	2797
370HD03	370HE03	125	135	230	130	185	190	3268
370HD04	370HE04	135	145	240	140	195	200	3598
370HD05	370HE05	145	155	245	150	205	205	3853
370HD06	370HE06	155	165	260	160	215	220	4291

Performance Data

Test Standard	BS EN 61914
Type	6.1.1 Metallic
Impact Resistance	6.3.3 V. Heavy
Lateral Load	50 kN
Axial Load	8kN
Needle Flame	>120 secs

* Technical Information subject to change without notice

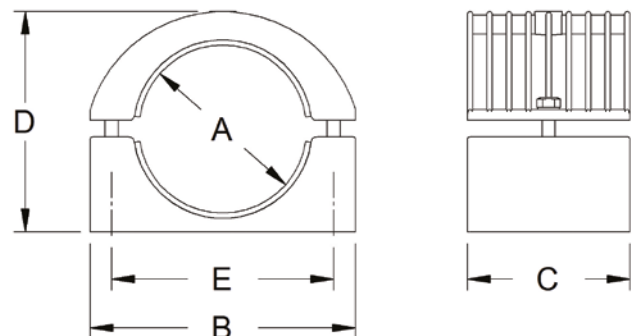



Orbit Cleat 379 series

- Suitable for use with cable diameters 33 to 150mm.
- Single bolt fixing with reversible base for range taking.
- Operating temperatures -40°C to +120°C.
- Ergonomic design allows easy installation, with single tool tightening from the top side.
- Manufactured from non-magnetic, corrosion resistant 316L stainless steel.
- Liners are made from LSOH materials.
- Suitable for use with single and multicore cables with high fault current requirements.
- Suitable for standard and LSOH cable sheaths.
- Can be used in harsh environments.
- Can be used with all standard ladder and tray systems.
- Complies with BS EN 61914.

SINGLE WAY CLEATS

Technical Data

Cleat Selection			Cleat Details			
Design Number	Cable Diameter		Dimensions (mm)			
	A (mm)		B Max	C	D	Weight (g)
	Min	Max				
379SC01	33	40	65	86	60	435
379SC02	38	46	71	92	60	467
379SC03	45	53	78	99	60	499
379SC04	52	60	85	106	60	530
379SC05	59	67	92	113	60	526
379SC06	66	74	99	120	60	558
379SC07	72	82	111	132	60	639
379SC08	82	92	120	141	60	683
379SC09	92	103	130	151	60	737
379SC10	103	113	139	160	60	784
379SC11	113	123	148	169	60	850
379SC12	122	132	157	178	60	865
379SC13	131	141	165	177	60	908
379SC14	140	150	175	196	60	950

All cleats have a single central fixing hole for a 12mm diameter fixing bolt.

Performance Data

BS EN 61914	Clause	Classification
Type	6.1.3	Composite
Operating Temperature	6.2	-40 °C to + 120 °C
Impact Resistance	6.3	V. Heavy
Needle Flame	10.1	>120secs
Corrosion	6.5.2	High, Outdoor - wet conditions

* Technical Information subject to change without notice

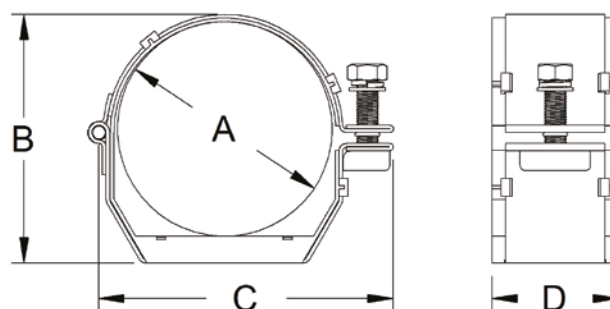



Firefix® Single Clip

- LUL Approved product register ID 1960.
- Nail fixed fire resistant clip.
- The Firefix™ system is fast easy and meets the cable support requirements of British standards: BS5839-1: 2002, BS5266-1:2011 and BS5839-8: 2006.
- Designed to be used with the Spit Pulsa™ gas nailing technology for rapid installation.
- Made from corrosion resistant stainless steel which is coated with an intumescent LSOH coating in either white or red to match the cable.
- Should be installed in accordance with BS7671 / IEE wiring regulations, or other appropriate code.
- Can be fixed to steel, block work, composite steel decking, brick or concrete.
- The fixing of the clip and installation of the cable takes just 10 seconds.

Kit Selection

Kit contents : Clips, ITW Nails and gas cartridge



Clip Selection				Clip Details							
Design Number		Cable Diameter		Installed Dimensions			Nail	Kit	Weight Ea	Kit Weight	
Standard	Colour	A (mm)		(mm)			Size	Qty	(g)	(Kg)	
		Min	Max	Height	Width	Length					
FPNF01R	Red	7.7	8.2	13.6	13.8	15.3	17mm	500	4.4	2.5	
FPNF01W	White	7.7	8.2	13.6	13.8	15.3	17mm	500	4.4	2.5	
FPNF01R15	Red	7.7	8.2	13.6	13.8	15.3	15mm	500	4.2	2.5	
FPNF01W15	White	7.7	8.2	13.6	13.8	15.3	15mm	500	4.2	2.5	
FPNF03R	Red	8.2	9.2	13.6	13.8	15.3	15mm	500	4.2	2.5	
FPNF03W	White	8.2	9.2	13.6	13.8	15.3	15mm	500	4.2	2.5	

Nailing tool sold separately. Part No: PULSA800E

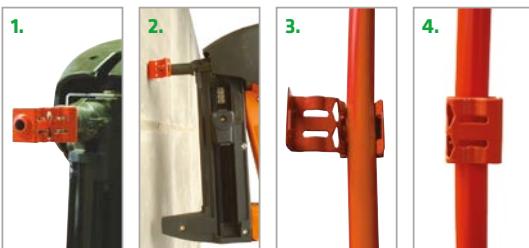

Installation

1. Position the FIREFIX™ clip directly on to the nail guide (No adaptors required).
2. Ensure the substrate is clear before pushing the Spit Pulsa™ tool against the substrate, and nailing the clip into position.
3. Place the cable into the clip.
4. Close clip.



Firefix[®] Double Clip

- LUL Approved product register ID 1960.
- Nail fixed fire resistant clip.
- The Firefix™ system is fast easy and meets the cable support requirements of British standards: BS5839-1: 2002, BS5266-1:2011 and BS5839-8: 2006.
- Designed to be used with the Spit Pulsa™ gas nailing technology for rapid installation.
- Made from corrosion resistant stainless steel which is coated with an intumescent LSOH coating in either white or red to match the cable.
- Should be installed in accordance with BS7671 / IEE wiring regulations, or other appropriate code.
- Can be fixed to steel, block work, composite steel decking, brick or concrete.
- The fixing of the clip and installation of the cable takes just 10 seconds.

Kit Selection

Kit contents : Clips, ITW Nails and gas cartridge, pin guide adaptors



Clip Selection				Clip Details						
Design Number		Cable Diameter		Installed Dimensions			Nail	Kit	Weight Ea	Kit Weight
Standard	Colour	A (mm)		(mm)			Size	Qty	(g)	(Kg)
		Min	Max	Height	Width	Length				
FPNF02R	Red	7.7	8.5	15	21.6	25.4	17mm	500	8.9	4.5
FPNF02W	White	7.7	8.5	15	21.6	25.4	17mm	500	8.9	4.5
FPNF02R15	Red	7.7	8.5	15	21.6	25.4	15mm	500	8.7	4.45
FPNF02W15	White	7.7	8.5	15	21.6	25.4	15mm	500	8.7	4.45
FPNF04R	Red	8.5	9.0	15	21.6	25.4	17mm	500	8.9	4.5
FPNF04W	White	8.5	9.0	15	21.6	25.4	17mm	500	8.9	4.5
FPNF04R15	Red	8.5	9.0	15	21.6	25.4	15mm	500	8.7	4.45
FPNF04W15	White	8.5	9.0	15	21.6	25.4	15mm	500	8.7	4.45

Nailing tool sold separately. Part No: PULSA800E

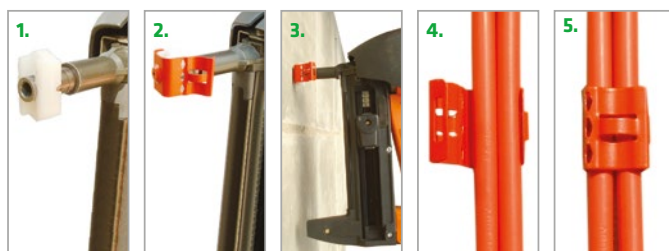

Installation

1. Attach adaptor to Pulsa™ tool.
2. Position the FIREFIX™ clip on to the adaptor.
3. Ensure the substrate is clear before pushing the Spit Pulsa™ tool against the substrate, and nailing the clip into position.
4. Place the cable into the clip.
5. Close clip.

FIRE RESISTANT CLEATS



AP Clips

- Suitable for Prysmian FP200 Gold®, FP Plus™, FP Plus Flex™ and Afumex LSX™.
- Suitable for Draka FT30, FT120 and FT Data.
- Securely holds one cable - ideal for a single cable run.
- Made from BS EN 1652 copper strip.
- Fire tested with FP cables.
- Finished with a red or white LSOH polyester coating.
- Ideal for visible installations.
- Meets the cable support requirements of BS 5839-1:2002+A2:2008.

Technical Data



Style	Clip Selection		Cable Diameter		Clip Dimensions (mm)				
	Design Number		(mm)		B	C	D	Ø E	F
	Red	White	Min	Max					
AP7	386PR07	386PW07	7.8	8.2	24	1.5	10	4.25	4.5
AP8	386PR08	386PW08	8.3	8.8	26	1.5	10	4.25	4.5
AP9	386PR09	386PW09	9	9.9	27	1.5	10	4.25	4.5
AP10	386PR10	386PW10	10	10.9	30	1.5	10	4.25	4.5
AP11	386PR11	386PW11	11	11.9	32	1.5	10	4.25	4.5
AP12	386PR12	386PW12	12	12.9	33	1.5	10	4.25	4.5
AP13	386PR13	386PW13	13	13.9	37	1.5	10	4.25	4.5
AP14	386PR14	386PW14	14	14.9	38	1.5	10	4.25	4.5
AP15	386PR15	386PW15	15	15.9	40	1.5	10	4.25	4.5
AP16	386PR16	386PW16	16	16.9	40	1.5	10	4.25	4.5
AP18	386PR18	386PW18	18	18.9	52	1.5	15	4.25	4.5
AP20	386PR20	386PW20	20	20.9	56	1.5	15	4.25	4.5
AP22	386PR22	386PW22	22	22.9	60	1.5	15	4.25	4.5
AP25	386PR25	386PW25	25	25.9	65	1.5	15	4.25	4.5

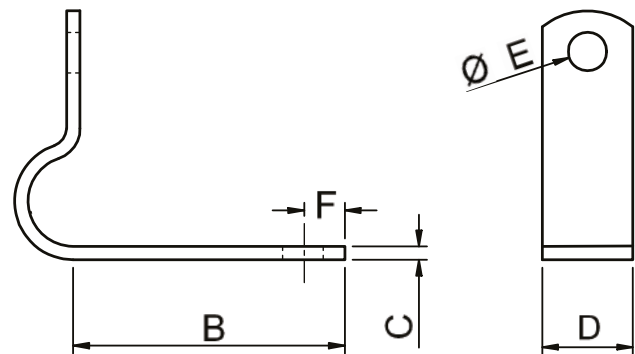



Claw Cleat (Cast Iron) 370 series

- Suitable for use with cable diameters 10 - 54mm.
- Hot dip galvanised finish on cast iron.
- Two-piece, single fixing design.
- Can be stacked to a maximum of three on one fixing.
- Operating temperature -60°C to +105°C.
- Can withstand a 2 hour excursion to 1000°C.
- Can be used for all types of cable routes.
- Suitable for all environments.
- Packing pieces to be used where required.
- LUL Approved product register ID 1961.
- Allows fire performance cables to meet the requirements of BS 6387:1994, BS 5839-1:2002, BS7346-6:2005 & BS8491:2008.

Technical Data



Cable and Cleat Selection			Cleat Details					
Design Number	Cable diameter		Dimensions (mm)				Weight (g)	Stud Size
	A (mm)		B	C	D	E		
	Min	Max	Max					
370CG01	10	13	22	38	46	16	227	M10
370CG02	13	16	22	38	46	16	208	M10
370CG03	16	19	25	41	46	18	232	M10
370CG04	18	22	28	45	46	19	279	M10
370CG05	21	26	32	48	46	21	299	M10
370CG06	25	32	37	54	46	24	319	M10
370CG07	31	38	43	60	46	27	395	M10
370CG08	36	46	53	67	46	30	492	M10
370CG09	44	54	59	73	46	33	502	M10

Method of Fixing

In all applications the cleats should be mounted on suitable fixings, see table for appropriate size. When mounting directly on channel, adaptor plates 380AG02 should be used. When stacking claw cleats use packing piece 389AC01 between cleats. (Please see page 39 for selecting both of these items).

Performance Data

Test Standard	EN 50368:2003
Type	6.1.1 Metallic
Impact Resistance	6.2.5 V. Heavy
Lateral Load	3.7 -> 8.2 kN
Axial Load	1.332 -> 5.855 kN
Needle Flame	>120 secs

* Technical Information subject to change without notice

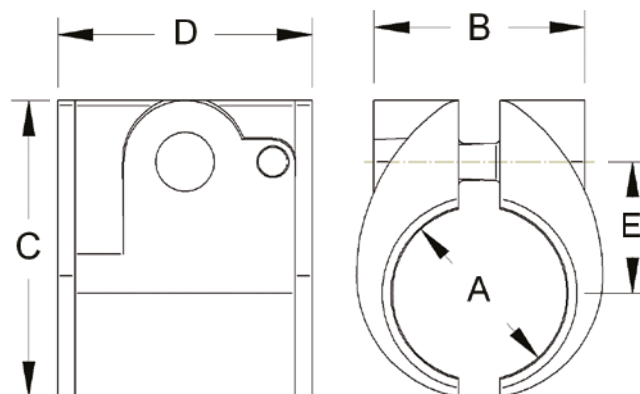



Two Bolt Cleat (Cast Iron) 370 series

- Suitable for use with cable diameters 51 - 89mm.
- Hot dip galvanised finish on cast iron.
- Two-piece, two fixing design.
- Can be double stacked on common fixings.
- Operating temperature -60°C to +105°C.
- Can withstand a 2 hour excursion to 1000°C.
- Can be used for all types of cable routes.
- Suitable for all environments.
- LUL Approved product register ID 1964.
- Allows fire performance cables to meet the requirements of BS 6387:1994, BS 5839-1:2002, BS7346-6:2005 & BS8491:2008.



Technical Data

Cable and Cleat Selection			Cleat Details					
Design Number	Cable diameter		Dimensions (mm)				Weight (g)	Stud Size
	A (mm)		B	C	D	E		
	Min	Max	Max					
370CG10	51	59	75	98	49	76	902	M10
370CG11	54	62	78	102	49	80	892	M10
370CG12	57	65	81	105	49	82	854	M10
370CG13	62	70	89	137	64	114	1155	M10
370CG14	68	76	95	140	64	114	1245	M12
370CG15	74	82	102	140	64	114	1300	M12
370CG16	80	89	108	140	64	114	1582	M12

Method of Fixing

In all applications the cleats should be mounted on suitable fixings, see table for appropriate size. When mounting directly on channel, adaptor plate 380AG02 should be used. (Please see page 39).

Performance Data

Test Standard	EN 50368:2003
Type	6.1.1 Metallic
Impact Resistance	6.2.5 V. Heavy
Lateral Load	18.1 kN
Axial Load	11.4 kN
Needle Flame	>120 secs

* Technical Information subject to change without notice

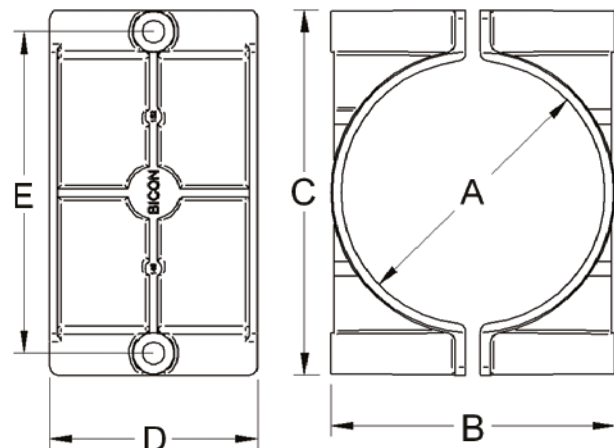



Multicleat/Multistrap System 378 series

- Suitable for use with cable diameters 24 to 145mm.
- Large range take on each size.
- Single or double bolt fixing.
- Operating temperatures -60°C to +105°C.
- All straps manufactured from non-magnetic 316L stainless steel.
- Plain aluminium bases - for normal industrial areas or outdoor unpolluted areas.
- Epoxy coated aluminium versions or stainless steel available for harsher environments.
- Bespoke tensioning adaptor included with every cleat and strap.
- Optional liners are available from LSOH material.
- Suitable for single core cables laid in trefoil formation with high fault current capacities.
- Suitable for use with all standard ladder and tray systems.
- Suitable for groups of dissimilar cables.
- LUL Approved product register ID 1996.
- Patent number 2082242.

Consisting of aluminium or stainless steel bases with a stainless steel strap complete with a tensioning clip the BICON™ Multicleat system offers the best flexibility for cable fixing available on the market today. With an unprecedented test portfolio and service record, the Multicleat system should be your first choice for trefoil and single cables installations requiring a high system fault current rating.

Multistraps are used as intermediate restraints and are positioned centrally between a pair of Multicleats. The standard and heavy duty products have different short circuit ratings related to their installation spacings. Please consult the following information in order to make the correct selection.

All Multicleats and Multistraps come with a disposable shear torque tensioning adaptor designed to aid the closure of the cleats and also better control the tension applied during installation. The adaptor fits into the open end of the winding pin and is used with a standard 13mm socket wrench. Any remaining slack in the strap is removed by rotating the pin and adaptor with the wrench until the adaptor shears off. This will also ensure that a consistent and correct torque is applied to every cleat and strap in the installation.

LSOH material liners are available for both the Multicleat and Multistrap, conforming to BS6853. The selection table helps to select the correct liner pack for the cleat or strap being used. Multicleats and Multistraps offer a high level of flexibility for use in unusual installations. See section on miscellaneous arrangements.

Installation Sequence



Fasten base to support with M10 fixings. Loop strap through base and around cables.
Standard duty = 2 loops.
Heavy Duty = 3 loops.



Pull slack into outer loop. Insert split pin from right hand side around outer layer of strap about 10mm from end. Push plastic shear torque adaptor fully onto the end of the split pin and attach 13mm socket wrench. To tension the strap rotate key anti-clockwise with the socket wrench until the adaptor shears.



Remove the shear torque adaptor and wrench. Swing the key over and engage in slots in clip.

Multicleat

Base Options					Cable Size					Liner	Two Bolts							
Two Bolts			Single Bolt				Trefoil ⌘		Single O		37LSF	AB / AD				JB		
Aluminium	Aluminium Epoxy Coated	Stainless Steel	Stainless Steel	Standard	Heavy Duty	Minimum Individual Cable Diameter (mm)	Maximum Individual Cable Diameter (mm)	Minimum Individual Cable Diameter (mm)	Maximum Individual Cable Diameter (mm)	Max Width C (mm)		Hole Centres D (mm)	Weight (kg) Standard Duty (01-09)	Weight (kg) Heavy Duty (01-09)	Max Width C (mm)	Hole Centres D (mm)	Weight (kg) Standard Duty (01-09)	
378	AB	AD	JB	PF	01	51	24	34	36	65		01	126	100	0.468	0.54	120	100
					02	52	30	41	60	85	126		100	0.479	0.57	120	100	0.641
					03	53	37	47	80	90	122		100	0.520	0.576	126	100	0.727
					04	54	43	54	85	110	122		100	0.535	0.595	126	100	0.742
					05	55	50	60			132		100	0.569	0.636	132	100	0.757
					06	56	56	67			132	100	0.583	0.657	132	100	0.771	
					07	57	63	73			176	150	0.716	0.798	152	125	0.94	
					08	58	69	80			176	150	0.729	0.818	152	125	0.953	
					09	59	N/A	N/A	105	120	122	96	0.547	0.614	126	100	0.754	
					36	72	85				230	200	-	0.832	230	200	-	
					37	82	95				230	200	-	0.864	230	200	-	
					38	92	105				284	242	-	1.449	230	200	-	
					39	102	115				284	242	-	1.480	290	250	-	
					40	112	125				284	242	-	1.511	290	250	-	
					41	122	135				284	242	-	1.542	290	250	-	
					42	132	145				290	242	-	1.572	290	250	-	

Example ordering code: 378 AD 58 Multicleat with a 377 LSF 02 Liner

Multicleat/Multistrap Selection and Spacing for Fault Current Rating

Multicleat / Multistrap	Spacing 'b' m Max	Short Circuit Current kA		Cleat Spacing at vertical change of direction (mm)
		rms	peak	
Standard Duty	1.8	51.8	114	300
Heavy Duty	1.5	59	130	300
Heavy Duty	1.2	71	184	300



Important note: To ensure adequate restraint, Multistrap **MUST** be used at the mid-point between cleats on all horizontal and vertical straight runs.

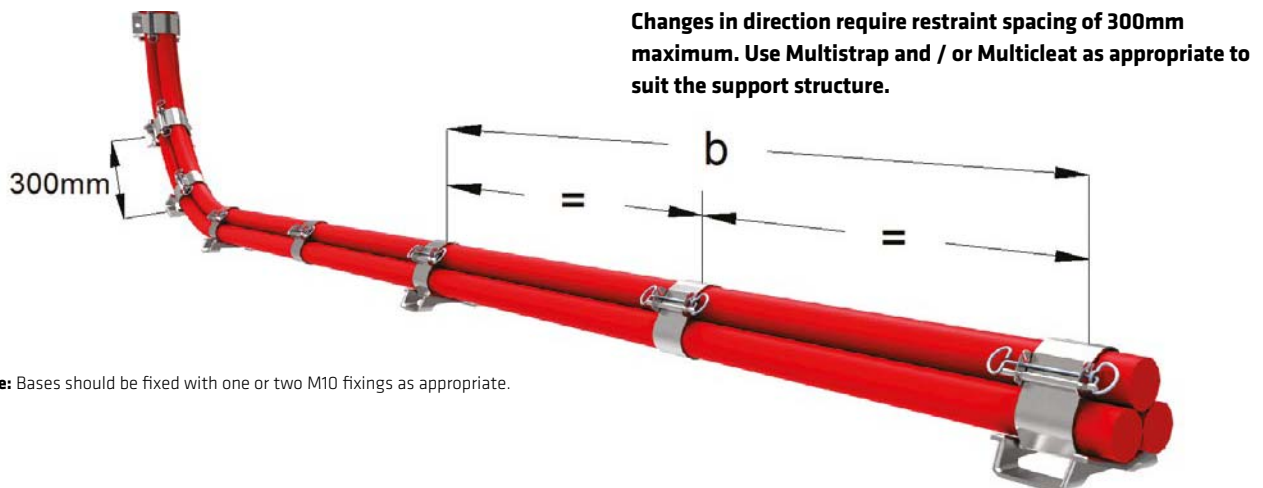

Note: Bases should be fixed with one or two M10 fixings as appropriate.

Multistrap

Dimensions and Weights									
Weight (kg) Heavy Duty (01-09)	AB or AD or JB		Single Bolt						
	Max Height Trefoil B (mm)	Max Height Single Cable B1 (mm)	PF						
			Base Width (mm)	Max Width Trefoil C (mm)	Max Width Single Cable C1 (mm)	Weight (kg) Standard Duty (01-09)	Weight (kg) Heavy Duty (51-42)	Max Height Trefoil (mm)	Max Height Single Cable B1 (mm)
0.669	95	92	76	76	76	0.480	0.519	99	96
0.668	100	113	76	82	85	0.491	0.538	113	116
0.783	121	118	104	104	104	0.566	0.622	121	118
0.802	135	138	104	108	104	0.581	0.641	135	138
0.824	146	-	120	120	-	0.634	0.701	147	-
0.845	160	-	120	134	-	0.648	0.722	161	-
1.022	172	-	146	146	-	0.890	0.972	173	-
1.042	186	-	146	160	-	0.903	0.992	187	-
0.821	-	148	104	-	120	0.593	0.660	-	148
1.454	190	-	-	-	-	-	-	-	-
1.486	210	-	-	-	-	-	-	-	-
1.520	230	-	-	-	-	-	-	-	-
2.551	250	-	-	-	-	-	-	-	-
2.582	270	-	-	-	-	-	-	-	-
2.613	290	-	-	-	-	-	-	-	-
2.643	315	-	-	-	-	-	-	-	-

Option	Cable Size				Weight		Liner		
	Standard	Heavy Duty	Trefoil &		Weight (kg) Standard Duty (01-08)	Weight (kg) Heavy Duty (51-42)			
			Minimum Individual Cable Diameter (mm)	Maximum Individual Cable Diameter (mm)					
377	AB	01	51	24	34	0.160	0.199	01	
		02	52	30	41	0.171	0.218		
		03	53	37	47	0.184	0.24		
		04	54	43	54	0.211	0.259		
		05	55	50	60	0.225	0.278	02	
		06	56	56	67	0.240	0.299		
		07	57	63	73	0.253	0.322		
		08	58	69	80	0.270	0.342		
				N/A	N/A				
				36	72	85		0.356	
				37	82	95		0.388	
				38	92	105		0.422	05
				39	102	115		0.453	
				40	112	125		0.484	06
		41	122	135		0.515			
		42	132	145		0.545			

Example ordering code: 377 AB 53 Strap with a 377 LSF 01 Liner

Two Bolt Type: AB, AD and JB

Base thickness 11mm

Single Bolt Type: PF

Base thickness 6mm

In all applications the Multicleat bases should be fixed with either one or two M10 fixings as appropriate

TREFOIL CLEATS

Miscellaneous Arrangements



Multicleat/Multistrap System

The Multicleat / Multistrap system is ideally suited for securing groups of cables of differing sizes. The Prysmian technical help team will be able to match the correct cleat /strap to for the size and fault rating of the cable arrangement.



Sirius Cleat 379 series

- Suitable for use with cable diameters 23 to 128mm.
- Single or double bolt fixing with reversible base for range taking
- Operating temperatures -40°C to +120°C.
- Ergonomic design allows easy installation, with single tool tightening from the top side.
- Manufactured from non-magnetic, corrosion resistant 316L stainless steel.
- Liners are made from LSOH materials.
- Suitable for single core cables laid in trefoil formation with high fault current requirements.
- Suitable for standard and LSOH cable sheaths.
- Can be used in harsh environments.
- Suitable for use with all standard ladder and tray systems.
- Complies with BS EN 61914.

Technical Data

Cleat Selection			Cleat Details				
Design Number	Cable Diameter		Dimensions (mm)				
	A (mm)		B	C (max)	D	E	Weight (g)
	Min	Max					
379TC01	23	28	86	71	60	Centre hole only	500
379TC02	27	32	92	78	60	25	531
379TC03	30	35	98	84	60	25	558
379TC04	33	38	102	90	60	25	585
379TC05	36	42	108	97	60	25	624
379TC06	40	46	115	105	60	25	657
379TC07	44	50	120	112	60	25	693
379TC08	48	55	129	121	60	50	734
379TC09	51	58	133	127	60	50	764
379TC10	55	62	140	134	60	50	795
379TC11	59	66	145	142	60	50	831
379TC12	63	70	150	150	60	50	869
379TC13	67	74	157	157	60	75	905
379TC14	71	78	164	164	60	75	939
379TC15	74	82	172	172	60	75	975
379TC16	77	85	178	178	60	75	1010
379TC17	82	88	184	184	60	100	1046
379TC18	88	96	200	198	60	100	1081
379TC19	96	103	214	210	60	100	1117
379TC20	103	111	230	225	60	125	1152
379TC21	111	119	245	240	60	125	1188
379TC22	119	128	264	257	60	150	1223

All cleats have a single central fixing hole for a 12mm diameter fixing bolt. Styles 02 to 22 can be also fixed with 2 x 10mm bolts - the 10mm clearance holes are positioned either side of the central hole with centres as per dimension D.

Performance Data

BS EN 61914	Clause	Classification
Type	6.1.3	Composite
Operating Temperature	6.2	-40 °C to + 120 °C
Impact Resistance	6.3	V. Heavy
Needle Flame	10.1	>120secs

	Clause	Classification
Resistance to Short Circuit	6.4.3(1 short circuit)	80.0kA rms, 175kA peak, Ø=36mm Spacing = 300mm
	6.4.4 (2 short circuit)	79.5kA rms, 175kA peak, Ø=36mm Spacing = 300mm 77.3kA rms, 170kA peak, Ø=36mm Spacing = 600mm
Corrosion	6.5.2	High, Outdoor - wet conditions

* Technical Information subject to change without notice

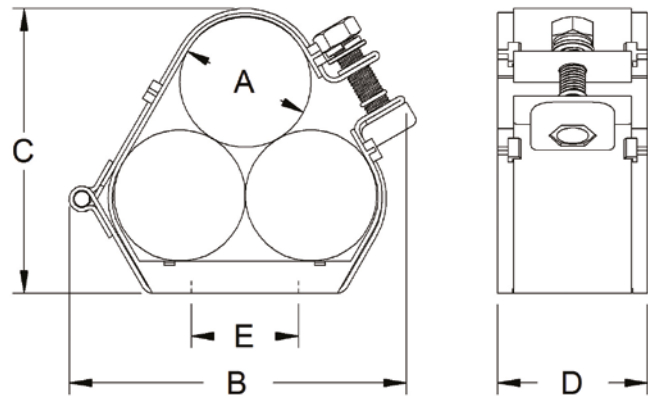



Orion Cleat 376 series

- Suitable for use with cable diameters 62-186mm.
- Manufactured from aluminium alloy.
- Suitable for use on LV, MV & HV cable designs.
- Single or two bolt fixing.
- Designed for use with larger diameter single core cables laid in trefoil formation.
- Deep section cast bases aid cable installation.
- Can be supplied with rubber liners.
- Profiled versions are available to meet specific design requirements.
- Tested in accordance with EN 50368:2003.

Technical Data

Cable and Cleat Selection				Cleat Details				
Design Number		Cable Diameter (mm)		Dimensions (mm)			Fixing Size	Weight (kg)
Standard	Epoxy coated	Min	Max	A	C	B		
376TR06	376TE06	62	75	260	216	80	M12	2.484
376TR07	376TE07	75	90	295	251	80	M12	3.326
376TR08	376TE08	90	107	340	296	100	M12	4.168
376TR09	376TE09	107	129	390	346	100	M12	4.951
376TR10	376TE10	129	155	450	406	125	M12	9.500
376TR11	376TE11	155	186	525	481	150	M12	11.536

Note 1: All cleats have the facility for single or two bolt fixing for M12 bolt. If 2 bolt fixings are used a minimum grade of 8.8 must be selected
 Note 2: 376TR11 and 376TE11 have four fixing bolts. Dimension C as above with 70mm between the bolts.

TREFOIL CLEATS

Performance Data

BS EN 61914	Clause	Classification
Type	6.1.1	Composite
Operating Temperature	6.2	-40 °C to +105 °C
Impact Resistance	6.3	Heavy
Needle Flame	10.1	>120secs

BS EN 61914	Clause	Classification
Resistance to Short Circuit	6.4.4 (2 short circuit) (HV Cable used)	31kA rms, 80kA peak
Corrosion	6.5.2	High, Outdoor - wet conditions (coating required for marine locations)

* Technical information subject to change without notice

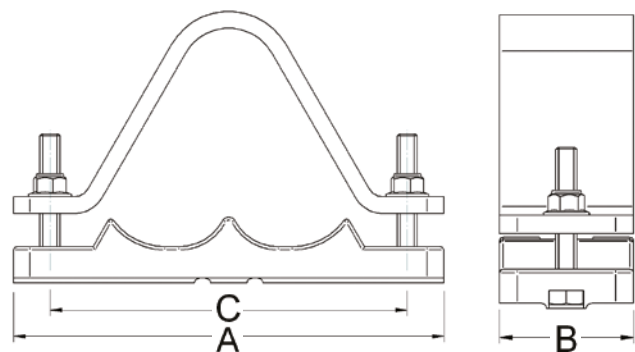



Orion Cleat - Shaped 376 series

Technical Data

Cable and Cleat Selection				Cleat Details				
Design Number		Cable Diameter (mm)		Dimensions (mm)			Fixing Size	Weight (kg)
Standard	Epoxy coated	Min	Max	A	C	B		
376SR05	376SE05	85	95	320	260	100	M12	3.4
376SR06	376SE06	95	105	340	280	110	M12	4.2
376SR07	376SE07	105	115	360	300	120	M12	4.9
376SR08	376SE08	115	125	380	324	130	M12	5.5
376SR09	376SE09	125	135	400	344	140	M12	6
376SR10	376SE10	135	145	420	370	150	M12	6.7
376SR11	376SE11	145	155	450	390	150	M12	7.6

Performance Data

BS EN 61914	Clause	Classification
Type	6.1.1	Composite
Operating Temperature	6.2	-40 °C to +105 °C
Impact Resistance	6.3	Heavy
Needle Flame	10.1	>120secs

BS EN 61914	Clause	Classification
Resistance to Short Circuit	6.4.4 (2 short circuit) (HV Cable used)	SR / SE 63kA rms, 164kA peak
Corrosion	6.5.2	High, Outdoor - wet conditions (coating required for marine locations)

* Technical Information subject to change without notice

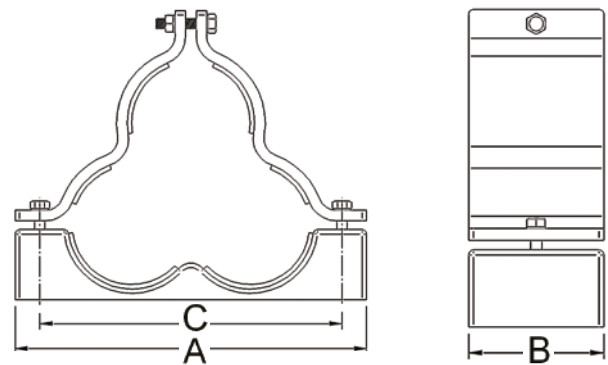



Libra Cleat 376AC series

- Suitable for use with cable diameters 24 to 76mm.
- Manufactured from aluminium alloy.
- Suitable for single core cables laid in trefoil.
- Can be used with all types of cable routes.
- Supplied complete with top fastening.
- Plain finish for indoor dry normal industrial use or outdoor unpolluted areas.
- Epoxy coated for harsher more hostile conditions.
- Operating temperature -60°C to +100°C.
- Suitable for use at a maximum system fault level of 30kA rms.

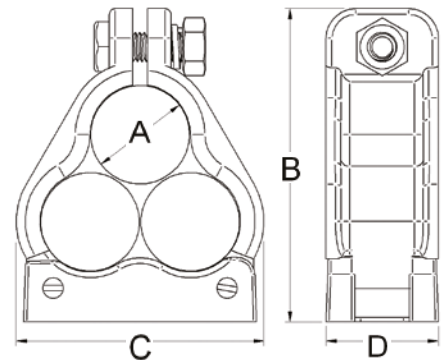

Technical Data

Cable and Cleat Selection				Cleat Details			
Design Number		Cable Diameter		Dimensions (mm)			Weight (g)
Standard	Epoxy Coated	A (mm)		B	D	C (Single Fixing)	Single Fixing
		Min	Max				
376AC01	376AE01	24	25	94	38	75	234
376AC02	376AE02	25	27	97	38	75	241
376AC03	376AE03	27	28	100	38	75	248
376AC04	376AE04	28	30	103	38	76	255
376AC05	376AE05	30	32	105	38	79	269
376AC06	376AE06	32	34	106	38	83	284
376AC07	376AE07	34	35	109	38	86	291
376AC08	376AE08	35	36	113	38	89	298
376AC09	376AE09	36	38	116	38	92	305
376AC10	376AE10	38	40	119	38	95	315
376AC11	376AE11	40	41	122	38	99	319
376AC12	376AE12	41	43	124	38	105	326
376AC13	376AE13	43	44	127	38	108	340
376AC14	376AE14	44	46	130	38	112	354
376AC15	376AE15	46	48	133	38	114	361
376AC16	376AE16	48	49	137	38	118	369
376AC17	376AE17	49	51	140	38	121	376
376AC18	376AE18	51	53	143	38	124	383
376AC19	376AE19	53	54	146	38	127	390
376AC20	376AE20	54	55.5	155	44	133	503
376AC21	376AE21	55.5	57	158	44	137	517
376AC22	376AE22	57	59	160	44	141	588
376AC23	376AE23	59	60	163	44	145	602
376AC24	376AE24	60	62	165	44	148	617
376AC25	376AE25	62	63.5	168	44	152	631
376AC26	376AE26	63.5	65	172	44	156	645
376AC27	376AE27	65	66.5	176	44	160	666
376AC28	376AE28	66.5	68	178	44	164	687
376AC29	376AE29	68	70	181	44	168	716
376AC30	376AE30	70	71.5	187	44	171	745
376AC31	376AE31	71.5	73	190	44	175	758
376AC32	376AE32	73	74.5	193	44	179	773
376AC33	376AE33	74.5	76	197	44	183	787

Two Bolt Version available on request



Orion Strap 376 series

Intermediate Short Circuit Straps

- Manufactured from 316L stainless steel.
- Includes rubber liner.
- Used in conjunction with the 376 Orion and 376 Orion-shaped cleats.

Please contact the Pysmian Technical team for assistance



Sirius Strap 379 series

- Made from 316L stainless steel.
- Comes with LSOH liners.
- Profiled to aid easy and quick installation.
- Single bolt closing.
- Used in conjunction with the 379 Sirius cleats.

Please contact the Pysmian Technical team for assistance

Performance Data

BS EN 61914	Clause	Classification
Type	6.1.3	Composite
Operating Temperature	6.2	-40°C to +120°C
Needle Flame	10.1	>120secs

BS EN 61914	Clause	Classification
Resistance to Short Circuit	6.4.4 (2 short circuits)	56.8kA rms, 125kA peak, Ø36mm, Spacing 300mm in conjunction with 379TC Sirius cleats.

*Technical Information subject to change without notice

TREFOIL CLEATS



Installation Equipment

Cable Rollers and Lifting Jacks

Designed with the same fixing arrangements as the 2 bolt and Shoe cleats. The rollers and lifting jacks facilitate cable system installation. The rollers can be configured in a variety of different ways – please speak to our technical team for more information.





System Repair Cleat

An innovative solution for the retrofitting of damaged cleats on old cables that cannot be moved. These custom-made retrofitting cleats can be provided on a rapid turnaround. These can be supplied with adjustable elements to overcome onsite variables.

Please contact the Prysmian Technical team for assistance



Auxiliary Stand-Off

Used to secure an auxiliary cable along the same route as an existing cable installation. Secured by the multi-strap system, the stand-off arrangement is made from a tough LSOH polymer. Used with rubber liners.

Contact the Bicon technical team to discuss your specific requirements



Miscellaneous Arrangements

Multicleat/Multistrap System

The Multicleat / Multistrap system is ideally suited for securing groups of cables of differing sizes. The Prysmian technical help team will be able to match the correct cleat /strap to the size and fault rating of the cable arrangement.



Cable Ties

Bundles of cables up to 100mm in diameter.
Available in black or natural finish.
Operating temperatures -40°C to +85°C.

Black Nylon Cable Ties

Cable and Cleat Selection		Cleat Details		
Design Number	Length (mm)	Width (mm)	Minimum Tensile Strength (kg)	Minimum Bundle Diameter (mm)
BB18S	96	2.5	8	19
BB40S	150	3.5	18	32
BB40L	203	3.5	18	50
BB50A	280	5.0	22	76
BB50S	190	5.0	22	44
BB50L	368	5.0	22	100
BB120S	380	8.0	54	100
BB120L	550	8.0	54	150

Natural Nylon Cable Ties

Cable and Cleat Selection		Cleat Details		
Design Number	Length (mm)	Width (mm)	Minimum Tensile Strength (kg)	Minimum Bundle Diameter (mm)
BN18S	96	2.5	8	19
BN40S	150	3.5	18	32
BN40L	203	3.5	18	50
BN50A	280	5.0	22	76
BN50S	190	5.0	22	44
BN50L	368	5.0	22	100
BN120S	380	8.0	54	100



Insulating Pad

Insulating pads are designed for use with the 379 series Sirius and Orbit cleats. They are designed to prevent bimetallic corrosion between the cleat and the substructure. They should be used in instances when installing a stainless steel cleat onto a galvanised steel substructure.

Insulating pad

Insulating Base	Suitable for cleat size	
	379TC-	379SC-
3900010	01 - 07	01 - 08
3900011	08 - 12	08 - 12
3900012	13 - 16	13 - 14
3900013	17 - 19	-
3900014	20 & 21	-
3900015	22	-



Adaptor Plate

Required when mounting smaller cleats directly onto 41mm wide channel.

Adaptor Plate

Reference Number	Adaptor Plate Description
380AG02	M10 (Galvanised)



Packing Piece

Required when stacking claw cleats.

Claw Cleat Packing Piece

Reference Number	Packing Piece Description
389AC03	aluminium alloy, plain
389AC04	aluminium alloy, epoxy coated